WHITE PAPER

Sustainable Transport

Electrifying the powertrains of industrial vehicles, transportation and marine



The immediate need to improve energy efficiency and reduce emissions

Transportation of people, goods and raw materials accounts for over 25% of the world's total energy consumption and almost 30% of carbon dioxide (CO₂) emissions worldwide.^{1,2} While the emissions from vehicles like passenger cars are often the first consideration given their high volume, non-rail transport of either people or goods like busses, ferries and industrial vehicles also have a significant impact. For example, in the EU, although trucks, busses and coaches account for less than 5% of traffic they account for about 25% of vehicle CO₂ emissions.³ In addition, diesel engines emit significant amounts of particulate air pollution, which can be harmful to people's health.

Given the urgency to reduce the impact on our planet, in addition to ongoing price and supply volatility of fuel, it is critically important for companies to transition to a sustainable transport approach to reduce both their emissions and energy consumption. To prevent irreversible climate change, the Intergovernmental Panel on Climate Change (IPCC) calculates that we must reduce the current level of carbon emissions by 43% by 2030.⁴ And to improve air quality, The World Health Organization (WHO) suggests steps that governments must now take, including implementing stricter vehicle emissions standards and modernizing public transport.

The electrification of public transport vehicles like busses has already proven to be effective in reducing emissions, and the technology is already mature and growing in popularity. In this white paper we take a look at the impact that continued use of fossil fuels will have on society and how the transition to electrification of powertrains in industrial vehicles, transportation and marine vessels can provide viable solutions.



Energy use and emissions by industrial vehicles

It is estimated that diesel-powered construction vehicles such as excavators, cranes and dozers collectively emit around 400 Mt of CO₂ per year. That amount accounts for approximately 1.1% of global CO₂ emissions. Of these construction vehicles, excavators over 10-tonnes in weight are responsible for close to a staggering 46% of those emissions.⁵ In addition to CO₂ emissions, diesel-powered vehicles also emit other harmful gasses and particulates. For example, in the US, it's been estimated that construction machines contribute to about 32% of mobile source NO_x emissions, which can form smog and exacerbate asthma and other health conditions.⁶ While in the construction industry in the UK, around 8% of occupational cancer cases are thought to be directly related to diesel engine exhaust emissions.⁷

Meanwhile, in underground mining, vehicles typically work in tight and enclosed spaces where a build up of exhaust gasses like CO₂ and NO_x can lead to hazardous situations for workers very quickly. As a result, underground mines that operate diesel-powered vehicles require extensive ventilation systems to extract the diesel exhaust fumes and make the air in working areas safe and breathable. And, although these ventilation systems are electrically powered, they still add to the overall energy consumption of the mine.

Given these environmental and health concerns, there is already a major effort across many industries to reduce emissions from vehicles including marine, materials handling and mining. Part of this effort in mining is being led by the International Council on Mining and Metals (ICMM) that has committed to achieving the goal of net zero greenhouse gas (GHG) emissions by 2050 or sooner.⁸ A major contributor to achieving this goal will be electrification. And, although the electrification of operational vehicles is relatively new in many industries, it can be an effective and realistic solution which is discussed later in this whitepaper.



— Mining has committed to achieving the goal of net zero greenhouse gas emissions by 2050 or sooner.

Energy use and emissions in transportation by road, rail and marine

The transportation of people and goods accounts for about 25% of the world's energy consumption.⁹ Over-land transport is provided mostly through road and rail vehicles, but we are also concerned with small-to-medium marine vessels such as ferries. This white paper does not cover aviation.

Road transport

While cars account for the majority of road transport emissions, busses and heavy-duty trucks also account for a significant proportion. For example, in the EU, heavy-duty trucks and busses account for 27% of emissions.¹⁰ As with industrial vehicles and machinery, diesel emissions from transportation vehicles have negative impacts on the climate, as well as on health. According to the WHO, air quality globally is at unsatisfactory levels and around 99% of the global population currently breathes air that exceeds the organization's recommended limits.¹¹

Since the majority of public transport routes operate in busy urban areas with dense populations, the effect of diesel emissions on air quality and public health is also a notable problem in many cities. In addition, diesel engines also generate a significant amount of noise and vibration, which also impacts health and wellbeing, and can lead to issues like cardiovascular disease and sleeping difficulties.¹²

Rail transport

Rail transport is significantly more efficient than road transport. While railways account for 9% of the world's passenger transport and 7% of freight transport, they only account for 3% of transport energy use.¹³ Even when trains are powered by fossil fuels – usually diesel – they are, on average, nearly 12 times more energy efficient than cars per passenger kilometer and 8 times more efficient than trucks per tonne of freight.¹⁵ Nonetheless, many routes in the world are still served by diesel locomotives due to the difficulties in providing electrical infrastructure in remote locations.

CO₂ emissions from road transport in the EU (2019)¹⁰

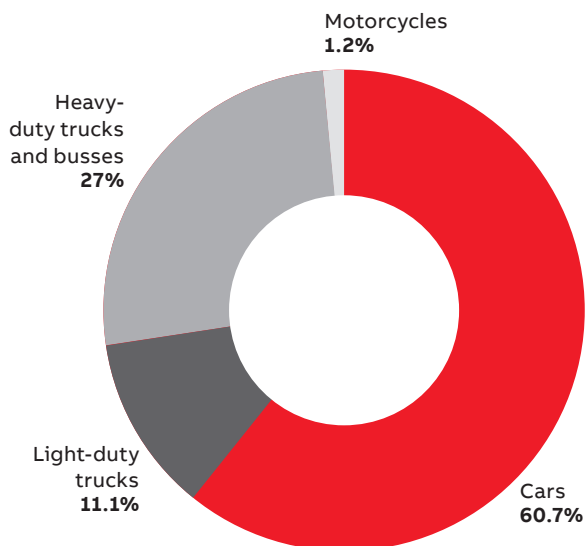

Global CO₂ emissions from transport by subsector (2020)¹⁴

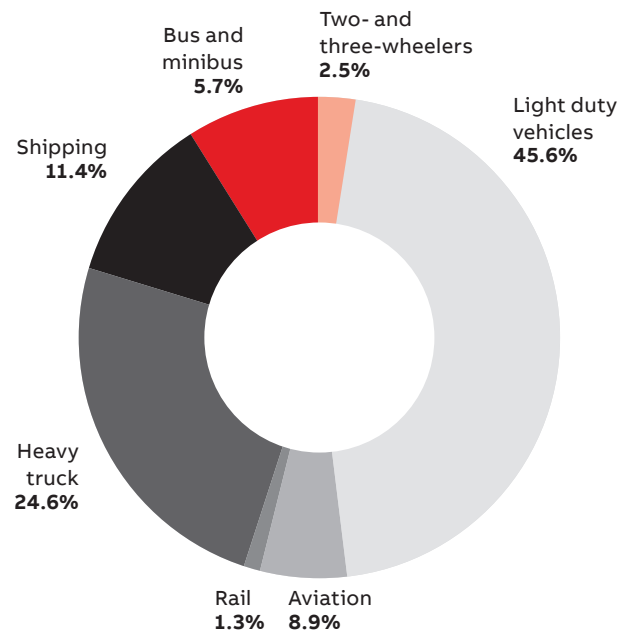

Marine transport

The transportation of people and goods by sea is also a significant source of greenhouse gas emissions and energy consumption. International and domestic shipping in the EU accounts for about 3.6% of total transport emissions, and has seen an increase in emissions of 32% over the past 20 years, representing the fastest growth in the transport sector (along with aviation). Emissions from shipping are projected to increase by 2050 to between 50% and 250%, resulting in a potential responsibility for 17% of global greenhouse gas emissions.^{16,17} This is mainly due to the diesel engines that are ubiquitous among these vessels. Due to this expected growth, increasing the energy efficiency and sustainability of marine operations is of paramount importance.

However, transporting goods by sea is still more efficient than transporting goods by road or air and generates lower CO₂ emissions. And although 85% of international freight is carried by ship, it accounts for only 2-3% of global CO₂ emissions. In comparison, road transport produces over 50% of all trade-related freight emissions.^{18,19}

Now that the inefficiencies and risks associated with diesel emissions are more widely known, there is increasing pressure to find more efficient, more sustainable alternatives. There are already many initiatives underway that promote the decarbonization of transport, including the European Commission's Sustainable and Smart Mobility Strategy, which aims for 90% lower transport sector emissions by 2050.²⁰

For land-based vehicles, electric powertrains offer an effective and proven way to both reduce emissions and to improve efficiency of transport. In the marine industry, fully electric propulsion systems can also improve efficiency and they are already available for small to mid-sized vessels. For larger vessels, full electrification is more difficult. However new and more sustainable fuels are being researched. For example, biofuels like bioethanol, as well as e-fuels synthetic hydrocarbons produced using renewable feedstocks and renewable energy. In addition, companies like ABB offer technology to improve efficiency and reduce fuel consumption. For example, the ABB Azipod® propulsion system can reduce fuel consumption by up to 20% compared to a traditional shaft line setup.^{21,22}

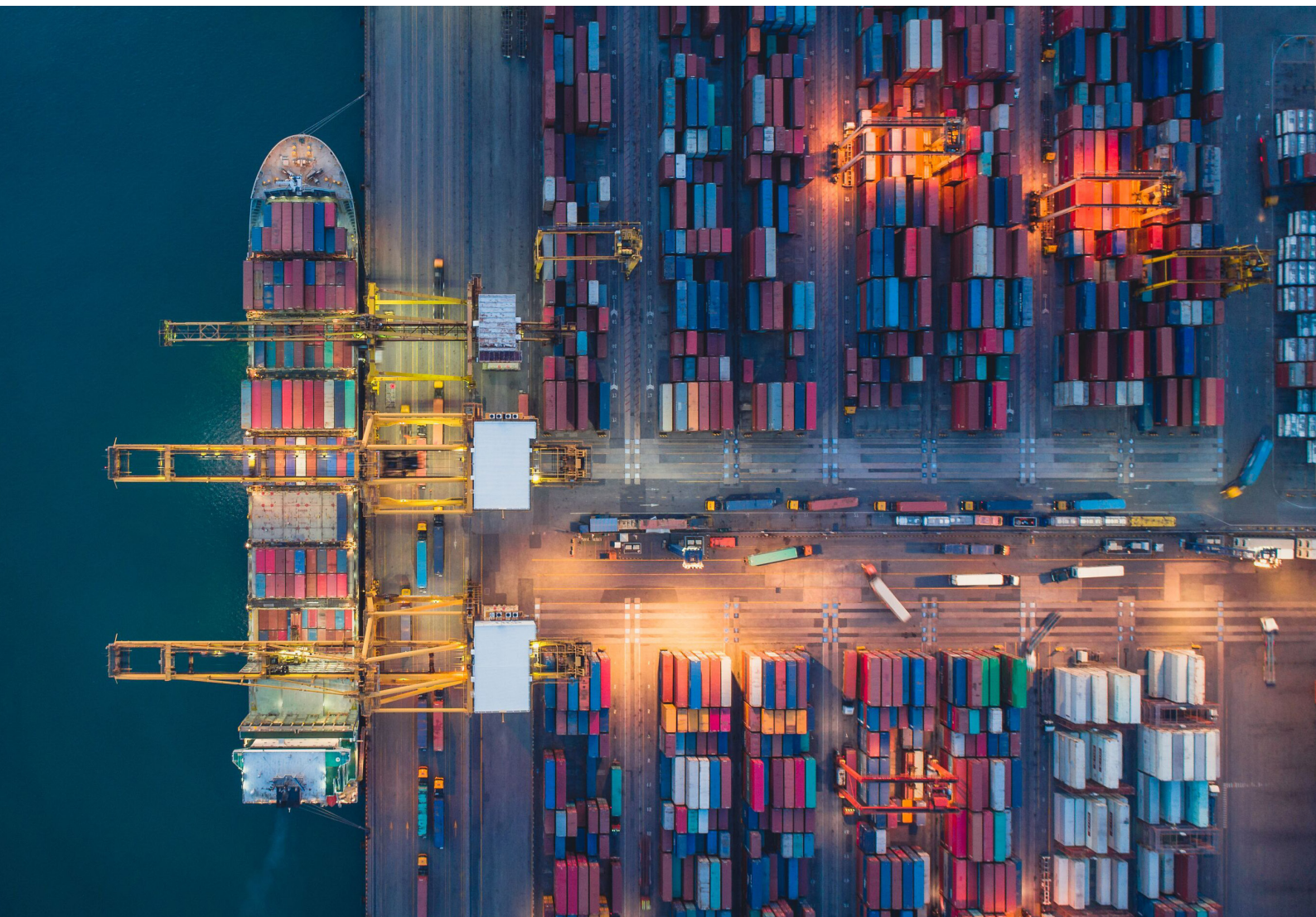

Supplying power to electric vehicles

Electrically-powered vehicles are those that use electricity as their primary source of energy rather than liquid fuels or gas, for example. To operate electrically-powered vehicles requires an infrastructure to support them, either to supply power directly or for recharging onboard batteries.

While the infrastructure for rail-based transport is already well developed, the infrastructure for road transport and marine applications is still under development, although this is proceeding quickly. The industrial situation is much more fragmented. In some industries, companies have already started to adopt electrically-powered heavy working machines and the associated infrastructure, whilst in others the concept is still in its relative infancy.

There are several different ways that industrial vehicles, transportation, and marine vessels can be powered with electricity, including via overhead catenaries, using rechargeable batteries, and using a combination of both catenaries and batteries, as well as with hybrid diesel-electric power.

Catenary power/Electrical trolley systems

Catenaries are overhead power lines which supply electricity to a vehicle traveling directly underneath them. The vehicle connects to the lines using a device on the roof called a pantograph. Although the range of this type of electric vehicle is limited to routes covered by overhead power lines, catenary-powered vehicles like trains and trolley busses are well proven in the public and goods transportation sector. For example, trains powered by catenaries are a familiar sight in many countries – they have been in use for well over 100 years – and they can haul large loads very efficiently.

One big advantage of catenaries is that they can provide the large amounts of power needed to operate very heavy vehicles, like locomotives, or even mining trucks. In recent years, catenaries have been trialed in open-cast mining sites to power heavy trucks.

Note: the term catenary is used for rail vehicles, trams, trolley-busses and busses, while for heavy working vehicles the term electrical trolley system is usually used.

Battery power

Transport vehicles that use rechargeable batteries have become more common in recent years in a number of cities as the recharging infrastructure and technology is advancing rapidly. However, it is important to note that the batteries required for industrial and transport vehicles and marine applications are different from the types of

batteries used in electric and hybrid passenger cars. The batteries used for those larger vehicles need to supply much more power (electricity), as well as enduring continuous use and withstanding many more charging cycles. For example, the average public transport vehicle such as a bus is in use for 16 to 18 hours a day, while the average passenger car is used for less than a 2 or 3 hours per day. Energy storage systems, which use powerful new lithium-ion battery technology, like the ABB BORDLINE® Energy Storage System (ESS), have been developed to meet the needs of heavy vehicles.

Battery-powered vehicles require their own infrastructure to enable recharging. Several different types of battery charging technology are already in use, including plug-in charging posts, catenary charging stations, catenary recharging while driving and using the electricity generated by the diesel engine in a hybrid system. Some vehicles also use removable batteries which can be swapped and recharged in a maintenance depot.



— ABB applied its eMine™ purposeful framework of methods and integrated solutions to design and install an effective electrical infrastructure to power several mine trucks at Boliden AB's Aitik mine in Sweden. The lane is ~700 meters and Boliden is expected to save ~830 m³ diesel per year and reduce its greenhouse gas emissions from transportation by up to 80 per cent along those routes where the technology can be implemented.

Combined catenary-battery power

Trains, trams and trolley-buses which can operate with both catenaries and batteries are also becoming more common. These vehicles use catenary power on routes with overhead power lines and switch to battery power on other routes. The ability to use both types of power source enables transport networks to extend the range of their fleet beyond the limits of the overhead lines. It also enables city bus routes to be expanded to cater for growing urban populations, making electric busses an option over cars where there is no rail network in place.

Modern systems, like ABB's Bordline® ESS system for trolley busses, use catenary power to recharge the batteries as the vehicle drives. On average, 1 km of catenary-powered driving enables 1 km of catenary-free driving, extending the vehicles' catenary-free range by 50%.²³

—
Modern systems use catenary power to recharge the batteries as the vehicle drives.

Hybrid diesel-electric power

Hybrid diesel-electric vehicles can operate using both diesel engines and electric motors. Depending on the type of vehicle, the electric power may be provided by catenaries or batteries, or from electricity generated by the diesel engine.

Hybrid diesel-electric power is particularly important for rail transport because a significant proportion of trains and still rely on diesel engines in areas where there is no catenary network available. For example, in the EU, although almost 100% of urban rail networks are electrified, only 60% of the mainline networks are.²⁴ This is because many long-distance transport routes carry a low density of traffic, which makes electrifying them economically unviable. Hybrid diesel-electric power also enables commuter trains to operate electrically in urban areas, while reverting to diesel power outside city limits.

Hybrid power systems are also an attractive option for marine vessels. For small and mid-sized vessels, diesel-electric drivetrains are already in use, while for larger vessels new types of hybrid systems are being developed. For example, super capacitors, as well as several different types of fuel cells are being researched that can be used together with electric propulsion systems. These include alkaline fuel cells, proton exchange membrane fuels cells, as well as hydrogen fuel cells.²⁵



—
Trolley-buses which can operate with both catenaries and batteries are becoming more common.

An overview of electric powertrains

Electric powertrains include several key components including an electric motor, which turn electrical power into motion, and a traction converter/inverter which regulates the voltage and frequency of the electricity that is supplied to the motor. Depending on the power source, other components will be needed. Batteries and charging outlets are required for battery powered vehicles, while DC/DC converters are required for catenary powered vehicles.

—

The components in a battery-powered electric wheel loader.

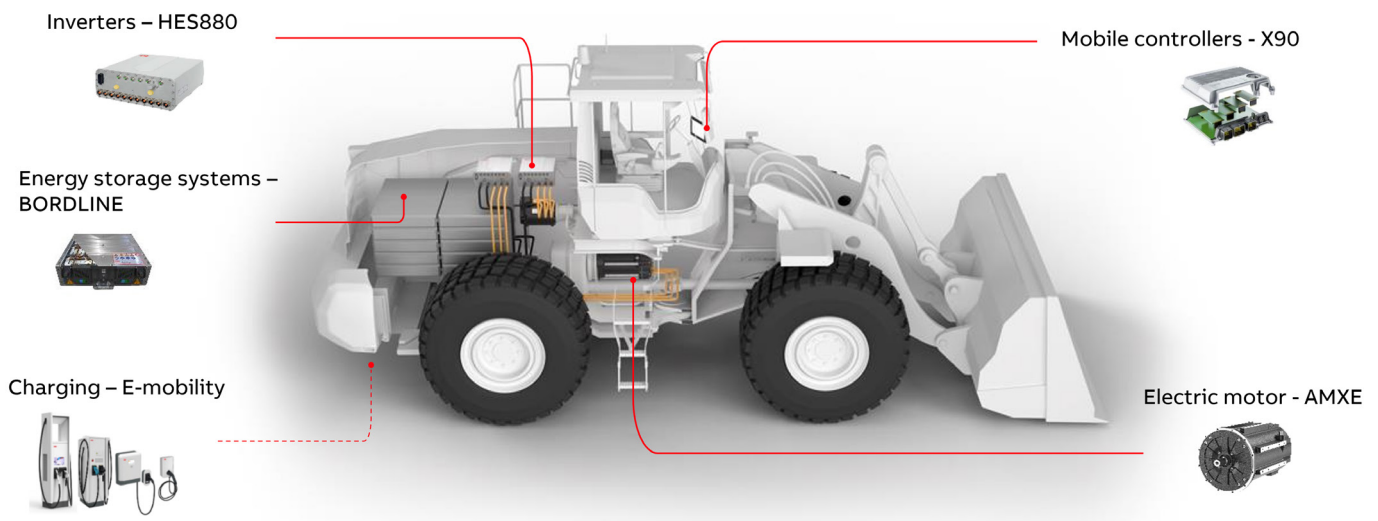

Electric motors

The electric motors for both industrial and transportation vehicles need to be robust, more powerful and have a longer working life than the smaller motors used in vehicles like passenger cars. Typically, they will be moving vehicles of 10 tonnes or more in weight and operate continuously over long working hours. This means they must be able to deliver high torque and perform efficiently at a wide range of loads. In addition, they must be designed to withstand all kinds of weather, a wide range of ambient temperatures, extreme working conditions, and shocks and vibrations. They are expected to have a long and productive working life.

These kinds of heavy duty motors have long been in use in rail transport, so the technology required is mature and proven, and it can be easily and effectively applied to

—

Electric motors must be able to deliver high torque and perform efficiently at a wide range of loads.

industrial vehicles as well. For example, the ABB AMXE® motors range are compact, permanent magnet synchronous motors for high efficiency propulsion and auxiliary usage, allowing configuration with specific lengths, windings and voltages to achieve the required performance.



ABB AMXE® motor for heavy vehicles

Traction inverters

A traction inverter converts the electrical supply from the power source into a variable voltage and variable frequency output to match the needs of the vehicle. Because this process affects all other components in the powertrain, it is important to choose a traction converter which operates efficiently.

For example, for transport vehicles like trolley-buses and trains, ABB's BORDLINE® Compact Converters are among the most efficient on the market. They allow total optimization of the traction transformer and motors, significantly reducing losses in the traction chain. In practice, this means that a typical commuter train can reduce its energy consumption and costs by up to 20%.²⁶

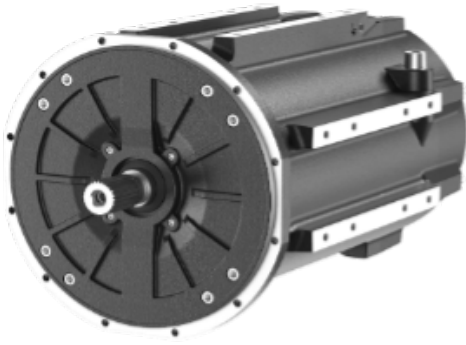
As another example, the ABB HES880 Mobile Drive provides similar efficiency benefits for heavy working machines, while also being built to withstand harsh working conditions and heavy operation.

Regenerative braking systems

Although electric motors are usually used to turn electric power into motion, when combined with the appropriate type of traction converter/inverter, they can also be used in regenerative braking systems to generate electricity. These systems recover the kinetic energy of the vehicle during braking.

A moving vehicle has kinetic energy, and for the same velocity, the heavier the vehicle, the more energy it will have. The heavier the vehicle, the more kinetic energy it has. To drive an electric vehicle, energy in the form of electricity is sent to the motors, which then rotate and move the wheels. In regenerative braking, the system works in reverse: the motion of the wheels is used to rotate the motors, which then generate electricity. The recovered electricity can then be stored either in an onboard battery or, if the vehicle is catenary powered, fed back into the network power supply for storage or use by other vehicles.

Note that regenerative braking uses the magnetic field in the motors to provide resistance and slow the vehicle down and to generate useful electrical energy. In contrast, mechanical braking relies on the friction created by brake disks or pads, which then lose and waste the energy as heat. This is why regenerative braking can make vehicles more energy efficient.

Regenerative systems are already used widely in both road and rail vehicles, where they can reduce energy consumption and costs. They are also becoming more common in electric industrial vehicles.



An electric bus equipped with ABB powertrain technologies in Zurich, Switzerland.

The drivers to transition towards building a sustainable transport fleet

When businesses set out to reduce their energy consumption and costs, a good starting point is to look at their operations overall, to identify inefficiencies at all phases of usage, including transport, idling, logistics and on-site work. This will help them identify which vehicles, vessels and machines would be the best fit to operate with an electric powertrain or other method. Companies like ABB have the expertise to advise companies on implementing electrification projects – whether that is starting with one operational vehicle or a whole fleet.

It is also worth noting that sometimes energy efficiency can be improved using relatively simple means, like training operators how to complete tasks efficiently and how to operate machines economically. This approach applies as much to operators in the works site as it does to directors in the board room – companies have to choose to be energy efficient.

Modern electric powertrains help make this choice easier. Using electricity instead of fossil fuels to power vehicles can significantly improve energy efficiency and drastically reduce emissions. For example, when operating in the optimum load range, diesel and petrol engines can reach efficiencies of 45% and 33%, respectively. In contrast, electric motors can typically reach about 95% efficiency.^{27,28} Traction converters/inverters can also control the speed and torque of an electric motor directly, rather than the clutches and gears required by internal combustion engines, which lose energy through friction and heat. And, in addition to gains in efficiency, electrification offers additional benefits to businesses, operators and the environment.

Better energy efficiency

The energy savings and efficiency gains for an electrically-powered vehicle or vessel vary depending on the technologies in use and on the application. However, the improvements can be substantial for industrial vehicles, transportation, and marine vessels, whether or not the vehicle is fully electric.

For example, when regenerative braking is used with a hybrid diesel-electric compaction roller, equipped with an onboard battery, the energy from braking is captured and stored. This energy can then be used by the electric motor to level out peaks in power demand, which in turn means that a smaller diesel engine is required, reducing fuel consumption by up to 30%.²⁹



Training operators in efficient machine use can result in fuel savings of up to 30%.³⁰

Alternatively, if the diesel engine is used to generate electricity, it can be operated in a steady state in its most efficient range, while the converter/inverter and electric motor handle variable loads. For large construction machines with this kind of system, fuel savings of up to 20% have been identified. And, if an electrical drivetrain is used in the same type of machine, instead of a mechanical one, together with an onboard energy storage system, it's been calculated that fuel savings of up to 30% could be reached.³¹

For heavy working vehicles with hydraulic systems, electric pumps can be used to power zonal hydraulics. Zonal hydraulic systems separate the areas of hydraulics into different working zones, for example, the hydraulics for drive systems, boom and buckets. This means that the pumps do not need to provide power to all the systems all of the time, which results in energy savings, because the hydraulic pumps do less work.

Meanwhile, for fully electric transport vehicles, like catenary powered trolley-busses, if a modern onboard energy storage system like the ABB BORDLINE® ESS is added it can improve the efficiency of regenerative braking, enabling energy savings of 15% compared to systems that feed energy back into the grid.³²

— Diesel and petrol engines can reach efficiencies of 45% and 33%, respectively. In contrast, electric motors can typically reach about 95% efficiency.^{27,28}

Reduced operating and ownership costs

On average, electric vehicles have 40% to 60% lower operating costs than equivalent vehicles powered by an internal combustion engine. This is mainly due to the improved tank-to-wheel efficiency and reduced fuel consumption, as well as the reduced maintenance needs. Although the initial investment price may be higher for an electric vehicle, the total cost of ownership over its working life is likely to be lower. For example, calculations indicate that total cost of ownership of battery powered electric heavy vehicles may be about 20% lower than for internal combustion engine powered equipment.³³

Reduced emissions

When powered by renewable sources of electricity such as solar or wind, electric vehicles produce no CO₂, NO_x or other emissions, nor do they emit any particulate pollution. Even when they use electricity supplied by fossil fuel-fired power stations, they still generate lower emissions overall, and no emissions or pollution in the area around the vehicle.

For example, if the diesel engine in a 24-tonne excavator is replaced by an ABB electric powertrain, which uses battery power together with an AMXE motor and HES880 drive, it can eliminate 48 tonnes of CO₂ emissions per year.³⁴

Higher productivity

Electric vehicles can increase the productivity of some applications. This is because electric motors are more efficient and deliver more power to the wheels. This is especially beneficial when heavy vehicles, like mine trucks, are hauling loads up hills – each unit of energy does more useful work per tonne, and the vehicle can drive faster but equally as safe. If the vehicles also have regenerative braking systems, they can recover significant amounts of energy on the journey back down the hill further reducing the energy consumption per tonne.



Electric vehicles can lower operating costs by **40-60%.**³³

Easier and safer to operate

Electrically powered systems can also give operators better control of heavy machinery. This is because electric systems respond instantly to operator input, giving them more accurate control and more feel for what the machine is doing, which makes them easier to operate. In contrast, traditional combustion engine powered hydraulic systems always have a small amount of lag, which makes operating them more demanding and slightly less precise.

Reduced ventilation and cooling needs

All internal combustion engines generate fumes and heat. On a working machine such as a ferry, the fumes are emitted through the exhaust pipe and the heat from the engine is managed and dissipated using radiators and fans. However, in an enclosed environment, like an underground mine, both the fumes and the heat have to be removed from the work area as well, using ventilation and cooling systems. As a result, as much as 40% of an underground mine's energy costs come from powering this type of ventilation system.³⁵

In contrast, electric vehicles emit no fumes and generate much less heat than diesel engines. This means that they can reduce cooling and ventilation requirements, and reduce energy consumption and the associated costs. It also means that fewer ventilation shafts are needed, which, in turn, reduces construction costs.



— Many different types of mining vehicles can be electrified.

Credit: Epiroc

Reduced noise and vibration

Large diesel engines create a lot of noise and vibration. The noise means that workers often have to wear ear protection and the vibration can lead to fatigue. In addition, the noise and vibration are disturbing to bystanders and, in built-up areas, working hours may be tightly regulated to minimize

disruption to the public. Electric motors are much quieter and generate much less vibration, which makes them much less fatiguing to operate. And, because they create much less disturbance, electrically powered machines can often be quiet enough to operate at night, even in densely populated areas. This also extends their productive working hours.

SUCCESS STORY



Nasta electrifies heavy construction machinery with ABB motors and drives

Nasta AS in Norway distributes, redesigns and rebuilds Hitachi diesel-driven construction machinery. It converts vehicles like excavators for operation using battery power or direct cable connection. The conversion procedure includes fitting ABB powertrain components such as electric motors and drives, together with an energy management system, battery and charging solution, along with a power connection.

Electrification of heavy vehicles provides clear environmental benefits. A diesel-driven 24-tonne excavator typically uses about 18,000 liters of fuel per year, which produces an annual total of around 48 tonnes of carbon dioxide emissions. After the upgrade, these CO₂ emissions are eliminated, as are sulfur oxide (SO_x) emissions, and the machines produce much less noise. These factors improve the environment, both for workers on the construction site and for people who live or work nearby. In addition, operators have told Nasta that the electrified machines are much more responsive when excavating.

SUCCESS STORY



ABB technologies help buses in Zurich become more sustainable

Energy-efficient drive solutions and energy storage systems from ABB are helping municipal public transport companies approach the goal of emission-free mobility.

Electric buses equipped with ABB powertrain technologies are significantly more sustainable than conventional diesel-powered vehicles. These are already on the road in cities across Europe, specifically line 83 of the Zurich public transport company (VBZ), which has been operating exclusively with electricity.

The buses operate through a combination existing catenaries and battery power. The energy storage system installed on the roof of the vehicle is recharged when the bus travels on existing sections equipped with catenaries. The dynamic recharging of the energy accumulator in particular guarantees great flexibility for cities with an extensive catenary infrastructure when it comes to expanding their network.

Conclusion

Although diesel is still used to power the majority of industrial vehicles and transportation, as well as marine vessels, solutions for electrification are advancing rapidly. Electric powertrains that rely on catenary and battery power, as well as diesel-electric hybrids, have already proven their worth and demonstrated clear efficiency and cost benefits in heavy vehicles like electric busses, trolley-busses and trains. Now the technology and know-how gained from these fields is increasingly being applied to industrial vehicles, transportation and marine. Thanks to progress in electrification, more efficient, lower emission industrial vehicles are now within reach.



1. U.S. Energy Information Administration, International Energy Outlook 2016, Executive summary, World delivered energy use by sector, page 13; [https://www.eia.gov/outlooks/ieo/pdf/0484\(2016\).pdf](https://www.eia.gov/outlooks/ieo/pdf/0484(2016).pdf)
2. <https://www.epa.gov/ghgemissions/sources-greenhouse-gas-emissions#transportation>
3. Electrification of Heavy Duty Vehicles, A Eurelectric statement, September 2017, page 1; https://www.eurelectric.org/media/2161/electrification_of_heavy_duty_vehicles-2017-030-0588-01-e.pdf
4. IPCC Press Release, April 4, 2022; <https://www.ipcc.ch/2022/04/04/ipcc-ar6-wgiii-pressrelease/>
5. <https://www.electricvehiclesresearch.com/articles/26187/electric-construction-machines-vital-for-greener-construction?stv1=1%3A410309%3A20716>
6. PROCEEDINGS OF THE IEEE, Vol. 109, No. 3, March 2021, page 280; <https://ieeexplore.ieee.org/document/9337910>
7. <https://www.electricvehiclesresearch.com/articles/26187/electric-construction-machines-vital-for-greener-construction?stv1=1%3A410309%3A20716>
8. ICMM CLIMATE CHANGE STATEMENT, October 2021; <https://www.icmm.com/en-gb/news/2021/net-zero-commitment>
9. U.S. Energy Information Administration, International Energy Outlook 2016, page 131; [https://www.eia.gov/outlooks/ieo/pdf/0484\(2016\).pdf](https://www.eia.gov/outlooks/ieo/pdf/0484(2016).pdf)
10. European Commission, Statistical Pocket book 2020, EU Transport in figures, page 157; <https://op.europa.eu/en/publication-detail/-/publication/da0cd68e-1fdd-11eb-b57e-01aa75ed71a1>
11. 99% of the world breathes air that exceeds recommended limits; <https://www.weforum.org/agenda/2022/04/poorer-nations-lag-behind-higher-income-countries-in-air-quality-standards-who/>
12. <https://www.euro.who.int/en/health-topics/environment-and-health/noise/publications/2018/environmental-noise-guidelines-for-the-european-region-2018>
13. IEA, Rail, Tracking report, November 2021; <https://www.iea.org/reports/rail>
14. <https://www.iea.org/reports/tracking-transport-2021>
15. IEA, The Future of Rail, Opportunities for energy and the environment, 2019, page 19; https://iea.blob.core.windows.net/assets/fb7dc9e4-d5ff-4a22-ac07-ef3ca73ac680/The_Future_of_Rail.pdf
16. European commission, Reducing emissions from the shipping sector; https://ec.europa.eu/clima/eu-action/transport-emissions/reducing-emissions-shipping-sector_en
17. Schnurr and Walker, Dalhousie University, Marine Transportation and Energy Use, 2019; https://www.researchgate.net/publication/335403999_Marine_Transportation_and_Energy_Use
18. The Carbon Footprint of Global Trade, OECD/ITF, 2015, page 8; <https://www.itf-oecd.org/sites/default/files/docs/cop-pdf-06.pdf>
19. European Commission, Electrification of the Transport System, Studies and Reports, 2017, Page 10; https://ec.europa.eu/newsroom/horizon2020/document.cfm?doc_id=46372
20. IEA, Trucks and Busses, Tracking report, November 2021; <https://www.iea.org/reports/trucks-and-buses>
21. ABB Generations magazine 2021, Future focus, Towards sustainable success, Fuel cells in commercial marine applications, page 186; https://library.e.abb.com/public/b48197614a6b304cc1257a8a003c3c43/ABB%20Generations_23%20Hybrid%20marine%20electric%20propulsion.pdf
22. <https://new.abb.com/news/detail/68041/electrified-thinking-redefines-shipping>
23. Based on ABB measurements and calculations.
24. European Commission, Electrification of the Transport System, Studies and Reports, 2017, Page 13; https://ec.europa.eu/newsroom/horizon2020/document.cfm?doc_id=46372
25. ABB Generations magazine 2021, Future focus, Towards sustainable success, Fuel cells in commercial marine applications, page 186; https://library.e.abb.com/public/b48197614a6b304cc1257a8a003c3c43/ABB%20Generations_23%20Hybrid%20marine%20electric%20propulsion.pdf
26. Based on ABB calculations and measurements.
27. https://en.wikipedia.org/wiki/Diesel_engine#:~:text=The%20highest%20diesel%20engine%20efficiency,two%2Dstroke%20watercraft%20diesel%20engines.
28. Jorge Martins, Francisco P. Brito, Delfim Pedrosa, Vitor Monteiro, João L. Afonso, Real-Life Comparison Between Diesel and Electric Car Energy Consumption, in Grid Electrified Vehicles: Performance, Design and Environmental Impacts, pp. 209-232, Nova Science Publishers, New York, 2013, page 5; ISBN 978-1-62808-839-7; <https://core.ac.uk/download/pdf/55627041.pdf>
29. CECE and CEMA, Optimising our industry 2 reduce emissions. Brochure, 2018, Page 29; <https://www.cece.eu/stream/cececo2booklet-1.3.pdf>
30. CECE and CEMA, Optimising our industry 2 reduce emissions. Brochure, 2018, Page 26; <https://www.cece.eu/stream/cececo2booklet-1.3.pdf>
31. CECE and CEMA, Optimising our industry 2 reduce emissions. Brochure, 2018, Page 12; <https://www.cece.eu/stream/cececo2booklet-1.3.pdf>
32. Based on ABB measurements and calculations
33. McKinsey & Company report, Harnessing momentum for electrification in heavy machinery and equipment, May 2019, page 13; https://www.mckinsey.com/~media/McKinsey/Industries/Automotive_and_Assembly/Our_Insights/Harnessing_momentum_for_electrification_in_heavy_machinery_and_equipment/Harnessing-momentum-for-electrification-in-heavy-machinery-and-equipment.pdf
34. Based on ABB customer experience.
35. EY, The future of electrified vehicles in mining, 2019 report, Mine electrification and Decarbonization, page 3



ABB Motion

P.O. Box 1
FI-00232
Helsinki, Finland